

CONCRETE MASONRY
INSTALLATION

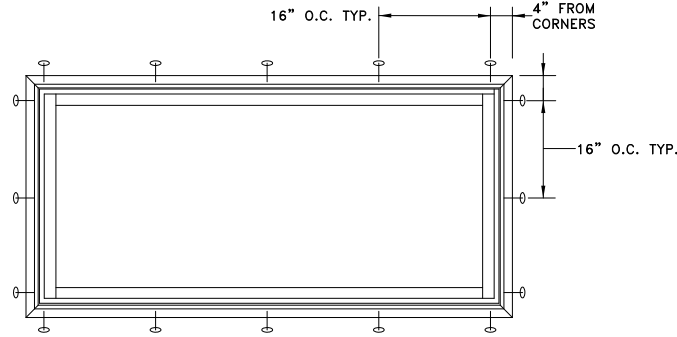

TYPICAL ELEVATION WITH FASTENER SPACING

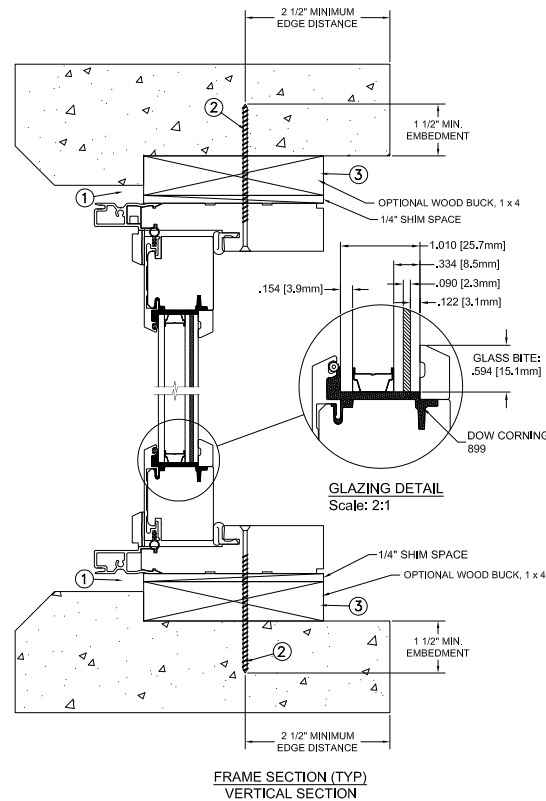

FRAME SECTION (TYP)
VERTICAL SECTION

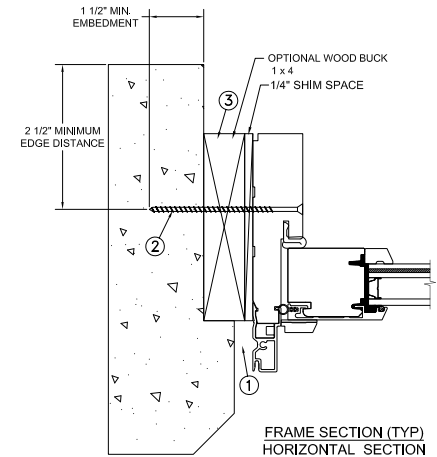

FRAME SECTION (TYP)
HORIZONTAL SECTION

Max Frame	DP	IMPACT
75 1/4 x 36	+50/-55	YES

Installation Notes:

1. Seal flange/frame to substrate.
2. Use 3/16" Tapcon or equivalent fasteners through frame with sufficient length to penetrate a minimum of 1 1/2" into concrete or masonry at each location with a 2 1/2" min. from edge distance. For concrete (min. fc = 3000 psi) or masonry substrate (CMU shall adhere to ASTM C90).
3. Host structure (wood buck, masonry, steel) to be designed and anchored to properly transfer all loads to the structure. The host structure is the responsibility of the architect or engineer of record for the project of installation.

General Notes:

1. The product shown herein is designed, tested and manufactured to comply with the wind load criteria of the adopted International Building Code (IBC), the International Residential Code (IRC), the Florida Building Code (FBC) and the industry standard requirement for the stated conditions.
2. Buck, framing and masonry by others and is responsibility of architect or engineer of record.
3. All glazing shall conform to ASTM E1300.
4. At minimum, glazing shall be 3.9mm tempered - 13.2mm airspace - 3.1mm annealed - 2.2mm PVB Interlayer by Dupont - 3.1mm annealed glass.

This schedule addresses only the fasteners required to anchor the window to achieve the rated design pressure up to the size limitations noted. It is not intended as a guide to the installation process and does not address the sealing consideration that may arise in different wall conditions. For the complete installation procedure, see the instructions packaged with the door or go to www.jeld-wen.com.

DISCLAIMER:

This drawing and its contents are confidential and are not to be reproduced or copied in whole or in part or used or disclosed to others except as authorized by JELD-WEN Inc.

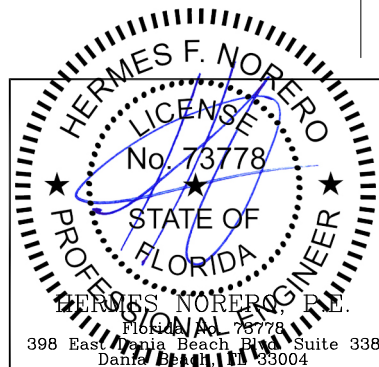

PROJECT ENGINEER: --	DATE: 08/07/2017	JELD WEN	3737 Lakeport Blvd Klamath Falls, OR. 97601 Phone: (800) 535-3936	
DRAWN BY: J.HAWKINS	SCALE: NTS			
CHECKED BY: C.GRAETSCH	TITLE: Siteline Clad OutSwing PD Impact Transom			
APPROVED BY: D.STOKES				
PART/PROJECT No.:	D011124			
IDENTIFIER No. SJW2016-051	PLANT NAME AND LOCATION: Hawkins, WI	CAD DWG. No.:	REV: A	SHEET
		SitelineCLOSWTran Cert		

MASONRY STRAP INSTALLATION

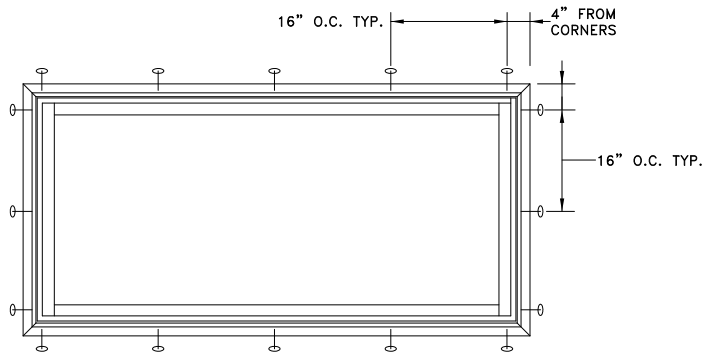

TYPICAL ELEVATION WITH FASTENER SPACING

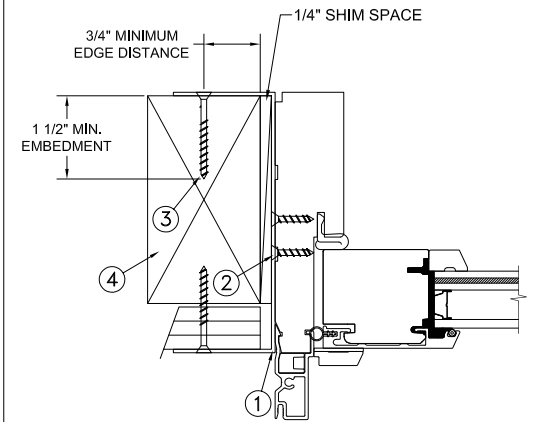
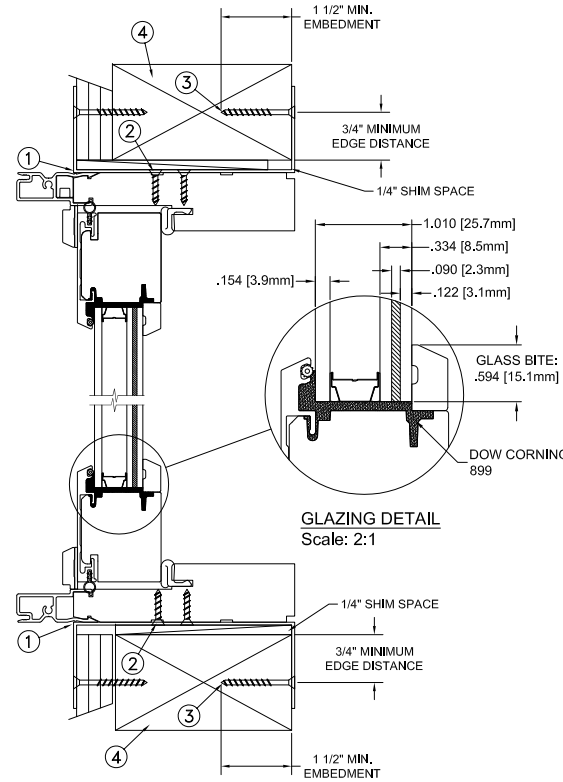

FRAME JAMB SECTION (TYP)
HORIZONTAL SECTION

Max Frame	DP	IMPACT
75 1/4 x 36	+50/-55	YES

Installation Notes:

1. Seal flange/frame to substrate.
2. Use min. 2 - #8 PFH or larger fasteners through masonry strap with sufficient length to penetrate a minimum of 1 1/2" into the buck. Bend straps around both sides of the buck.
3. Use min. 2 - #8 PFH or larger fasteners through masonry strap into jamb without penetrating through the jamb into product causing visibility or collateral damage to product.
4. Host structure (wood buck, masonry, steel) to be designed and anchored to properly transfer all loads to the structure. The host structure is the responsibility of the architect or engineer of record for the project of installation.

General Notes:

1. The product shown herein is designed, tested and manufactured to comply with the wind load criteria of the adopted International Building Code (IBC), the International Residential Code (IRC), the Florida Building Code (FBC) and the industry standard requirement for the stated conditions.
2. Buck, framing and masonry by others and is responsibility of architect or engineer of record.
3. All glazing shall conform to ASTM E1300.
4. At minimum, glazing shall be 3.9mm tempered - 13.2mm airspace - 3.1mm annealed - 2.2mm PVB Interlayer by Dupont - 3.1mm annealed glass.

This schedule addresses only the fasteners required to anchor the window to achieve the rated design pressure up to the size limitations noted. It is not intended as a guide to the installation process and does not address the sealing consideration that may arise in different wall conditions. For the complete installation procedure, see the instructions packaged with the door or go to www.jeld-wen.com.

DISCLAIMER:

This drawing and its contents are confidential and are not to be reproduced or copied in whole or in part or used or disclosed to others except as authorized by JELD-WEN Inc.

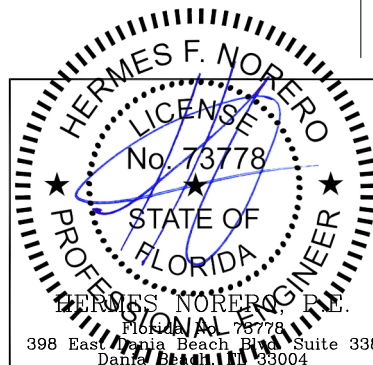

PROJECT ENGINEER: --	DATE: 08/07/2017	JELD WEN	3737 Lakeport Blvd Klamath Falls, OR. 97601 Phone: (800) 535-3936	
DRAWN BY: J.HAWKINS	SCALE: NTS			
CHECKED BY: C.GRAETSCH	TITLE: Siteline Clad OutSwing PD Impact Transom			
APPROVED BY: D.STOKES				
PART/PROJECT No.:	D011124			
IDENTIFIER No. SJW2016-051	PLANT NAME AND LOCATION: Hawkins, WI	CAD DWG. No.:	REV:	SHEET
		SitelineCLOSWTran Cert	A	